

RECKMANN

operation manual

RS2000
manual reefing system
aluminium foils
wire / rod



Stand: 15 March 2011

Copyright by
Reckmann Yacht Equipment GmbH
Siemensstr. 37-39
D-25462 Rellingen

1	Introduction	5
1.1.1	Packing list	5
1.1.2	How to use this manual	9
1.1.3	Important remarks	9
1.1.4	Furling line	10
1.1.5	Sailing with a reefed sail	10
1.1.6	Toggle	13
1.2	Maintenance of the furler	14
1.2.1	Maintenance to be carried out by the customer	14
1.2.2	Maintenance to be carried out by a Reckmann service partner	14
1.2.3	Furling systems with rod headstay after storage	14
2	Assembling the furling unit	16
2.1	Tools required for assembly	16
2.2	measurement A	17
2.3	Calculating B, C und D	18
2.4	table for L1	19
2.5	table for L2	20
2.6	Foil assembly from R10 up to R40	21
2.6.1	Preparation of the top cap	21
2.6.2	Shortening the top foil	22
2.6.3	Shortening the top hose	23
2.6.4	Assembly of bushings and spacer tubes	24
2.6.5	Foil assembly / split foil connectors	26
2.7	Installation of the foil reinforcement (optional)	27
2.7.1	Preparation of the headstay	27
2.7.2	Reinforcement assembly	30
2.8	Headstay length D	34
2.9	Assembly of swageless fittings	35
2.10	Dismantling the adjuster	36
2.11	Installing bottom bearing and halyard swivel	37
2.12	Assembly of halyard swivel and sail feeder for foils R10 up to R50	38

2.13	Connection of foils and drum.....	39
2.14	Securing the headstay in the furler.....	40
2.15	Assembly of the adjuster	41
2.16	Assembly of the top cap	42
2.17	Installing the furling line.....	43
2.18	Furling line lead	44
3	Operation of the furler.....	46
3.1	Length adjustment of the RS2000.....	46
3.2	Racing purposes.....	47
3.3	Configuration of the head	48
4	specification sheet RS2000	50
4.1	Reckmann aluminium foil sections.....	51
5	Dealer network and service stations.....	52
6	Index	58

1 Introduction

1.1.1 Packing list RS2000

Date _____

Customer _____

Dealer _____

Order number _____

Type: RS2000 _____

headstay type: _____ - size (mm, -): _____

headstay length: D= _____ mm unshortened foil length P: _____ mm

rod collets/

swage terminal: 1 pc topterminal: _____

halyard swivel: 1 pc ___ - shackle _____ pcs

tack slider _____ Shackle size: _____

Manual: 1 pc foil type (R/S): _____

Assembled axle with _____

Drum and drum guard _____

Furling line size _____

1 Feeder section*	<input type="checkbox"/>	3000 mm	<input type="checkbox"/>	5980 mm
___ Standard section	<input type="checkbox"/>	3000 mm	<input type="checkbox"/>	5980 mm
___ Standard section		1500 mm		
___ Top section		_____mm		

*length without furler spline and sliding tube

Introduction

R10 up to R40

___ Hose 200 mm

___ Hose 340 mm

___ Hose 500 mm (red marked)

___ Hose 600 mm

___ Hose 1740 mm

___ Top hose _____mm

R50 and R5 up to R8

___ Spacer tube 240 mm (at some sizes slotted)

___ Spacer tube 1660 mm (at some sizes slotted)

___ Splice bearing with two screws (at some sizes split)

___ Bottom bushing

___ Bearing for foil reinforcement (at some sizes split)

___ Bottom foil reinforcement

___ Foil connectors (at some sizes split)

___ Delrin bearings (2 spares up to R40), (at some sizes split)

___ SS inserts for foil connectors (1 spare)

___ Screw for foil connectors (2 spares)

1 Top cap with screws (split)

1 Bottom threaded plates with screws

1 Sail feeder

___ Key for stay adjustment

1 Set socket wrenches

___ Winch handle



Additional equipment:

Packed by

Introduction

Dear Reckmann customer,

With the RS2000 reefing system you have purchased the latest reefing system which you can rely on. This unit is manufactured using the latest technical innovations and uses the best materials. It is a successful combination of design, performance and safety. We are confident that the RS2000 reefing system will provide you with enjoyment for many years.

1.1.2 How to use this manual

Read this manual carefully before assembly and operation of your Reckmann gear.

Points that need additional attention will be marked in the following way:

**Note!**

This sign marks points which need special attention.

**Warning!**

This sign marks the risk of injuries or other significant danger.

**Tip**

this triangle marks useful tips.

1.1.3 Important remarks

After your furling system was installed accordingly to this manual, we recommend to read the following notes carefully before you set your furling system into operation.

**Note!**

Improper use according to this manual of the furler may cause loss of warranty.

Consult a Reckmann service partner in any case of problems.



Warning!

Any modification or damage may influence the safe operation of the furler.

Please make sure that the furling system is in a well condition according to this manual.

1.1.4 Furling line

When the jib is totally unfurled, it is advisable to make sure that there is always a slight tension on the furling line as otherwise the turns wound round the drum will become loose. When unfurling the sail, the furling line has to be led under slight tension. We recommend that a few turns remain on the drum when the sail is fully unfurled.



Tip

An untensioned furling line can slip down on the drum and cause the reefing line to get blocked. Please keep the furling line permanent under slight tension.

Release the sheet before the sail is furled.



Warning!

Furling the sail against a tensioned sheet may cause damages of the furler.

Release the sheet before you start furling the sail.

1.1.5 Sailing with a reefed sail

A furled sail necessitates a genoa fairlead individually positioned according to the shape of the furled sail. We therefore recommend the sail to be totally furled up, the genoa fairlead adjusted to its new position and then the sail

unfurled to the required size. Employ two sheets and two genoa fairleads. This will reduce the tension from the sheet when furling. In strong winds or with big boats where the furling line cannot be pulled by hand, never operate with a winch against the full tension of the sheet. When sailing with a furled jib, the furling line should be well secured as it keeps the furled sail in position preventing it from being unfurled by the sheet tension.

**Warning!**

High sheet loads and flapping sails may cause injuries while adjusting the tack points on the deck. To avoid the risk of injuries, furl the entire sail before tack point adjustment.

**Tip**

Too low halyard tension may cause a halyard wrap. A halyard wrap blocks the furling gear and may cause damages of the foils. Make sure that the halyard is under sufficient tension.

**Tip**

The genoa halyard has to be equipped with a swivel shackle. If the halyard gets twisted around the foil, the functioning of the furler will be impaired. As mentioned above, the swivel shackle enables the halyard to lose its twist.



Tip

Too low headstay tension causes sag of the headstay which reduces the performance of the boat.

Please make sure that your headstay tension is sufficient.

1.1.6 Toggle

The RS2000 was shipped with a bottom stay toggle. Make sure that the top end of the stay is also equipped with a toggle. It is necessary that a toggle is installed at both stay ends. Without toggle, the stay terminals would be damaged by fatigue due to bending moments.



Warning!

A forestay without toggle could break due to fatigue. Make sure that a toggle is installed at both stay ends.

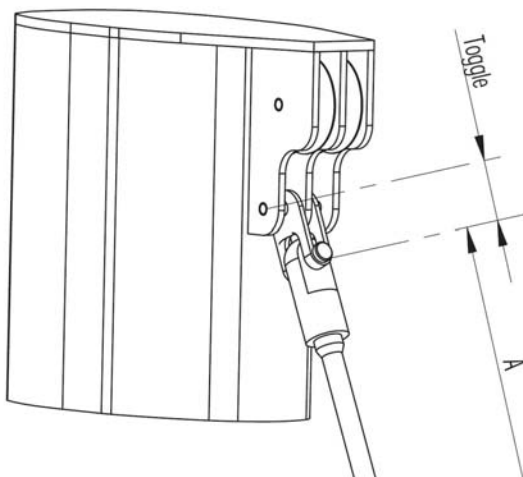

Note!

Luff tape remaining in the sail feeder at a fully hoisted sail may damage the feeder. Make sure that the luff tape ends above the feeder at a fully hoisted sail.

1.2 Maintenance of the furler

To keep the furler in a good optical and technical condition, a regular service is required. Maintenance of the furler consists of two basic points:

- Regular maintenance by the customer
- Regular Service performed by one of our service partners



Tip

Proper operation can only be ensured by regular service. Make sure that the maintenance plan of your furler is carried out carefully.

1.2.1 Maintenance to be carried out by the customer

Clean your furling gear regularly. Wash carefully all salt from the furler. Stainless steel parts can be treated with special care product. Additional for all electric and hydraulic furling units, the function of the manual backup drive and the condition of all hydraulic hoses / electric wires should be checked regular.

1.2.2 Maintenance to be carried out by a Reckmann service partner

To ensure the safe and proper operation of the furler, it has to be serviced every five years by an authorized Reckmann service partner. A table of all authorized Reckmann service partners can be found at the end of this manual or at www.reckmann.com

1.2.3 Furling systems with rod headstay after storage

After every mast dismantling ensure that the retaining brackets security screw (see chapter “assembly of the rod collets”) is still fixed. Therefore you have to withdraw the adjuster, dismantle the top

cap and push the headstay from the top to the bottom end out.



Warning!

A rod collet which is not in place, can cause the headstay breaking.
Every time the mast is stepped, you have to make sure that the collets are in place.

2 Assembling the furling unit

2.1 Tools required for assembly

Before assembling the reefing system, ensure that you have all the tools necessary. In addition to the allen keys enclosed with the system you will need:

- screwdriver
- cross head screwdriver
- drill
- 3.0 mm drill bit for R10 to R20 and
- 4.0 mm drill bit for R30 to R40
- 4.0 mm drill bit for S1 to S3
- 5,2mm drill bit for R50 and R5 to R8
- M6 thread drill for R50 and R5 to R8
- hacksaw
- sharp knife

2.2 measurement A

Prior to the assembly of the Reckmann RS 2000 Furler determine the length of the base measurement A. This measurement is the total length of the furling system measured from the centre pin hole of the masthead toggle to the center pin hole of the deck fitting. The whole calculation should be done in mm. All calculations in this manual allow for the length adjuster to be in its mid position on final assembly.

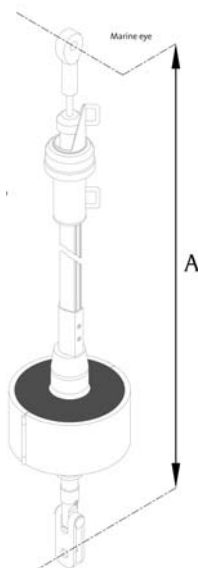

Adjuster stroke:

RS2000-10	60 mm
RS2000-20	60 mm
RS2000-30	70 mm
RS2000-40	80 mm

2.3 Calculating B, C und D

Please put the values for A, L1, L2 und P into the following calculation to get the measurements B, C and D.

The values L1 and L2 can be found in the following tables. Values A and P can be found in the packing list at the beginning of this manual. **All values in mm!**

B	=	A	-	L1	
	=		-		
C	=	P	-	B	
	=		-		
D	=	A	-	L2	
	=		-		

2.4 table for L1

Draht / wire	R10 sw	R10 st	R20 sw	R20 st	R30 sw	R30 st	R40 sw	R40 st
Ø6	521	551						
Ø7	541	559						
Ø8	561	566	589	599				
Ø10			605	625	648	678		
Ø12					705	717	797	849
Ø14							840	877

Rod	R10	R20	R30	R40
N8	551			
N10	551			
N12	559	594		
N17		600	665	
N22		620	690	
N30			720	833
N40				855
N48				882

(sw= Walz-/ swage terminal; st= Sta Lok terminal)

2.5 table for L2

Draht / wire	R10 sw	R10 st	R20 sw	R20 st	R30 sw	R30 st	R40 sw	R40 st
Ø6	244	276						
Ø7	244	278						
Ø8	244	280	247	283				
Ø10			253	295	287	329		
Ø12					306	356	376	416
Ø14							379	439

Rod	R10	R20	R30	R40
N8	257			
N10	256			
N12	255	258		
N17		264	306	
N22		264	315	
N30			333	381
N40				387
N48				405

(sw= Walz-/ swage terminal; st= Sta Lok terminal)

2.6 Foil assembly from R10 up to R40

2.6.1 Preparation of the top cap

Insert both half of the top cap into the top section and carefully drill a pilot hole (see table for d in the chapter preparations) on each side for the screws provided. Remove the top cap for installation later.

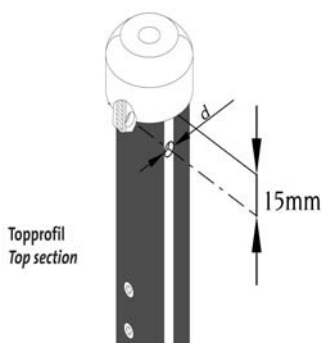

Required drill bit diameter for top cap assembly

R10	3 mm
R20	3 mm
R30	4 mm
R40	4 mm

2.6.2 Shortening the top foil

Shorten one of your 3000mm standard foils by the measurement C. This shortened foil is now your top foil.

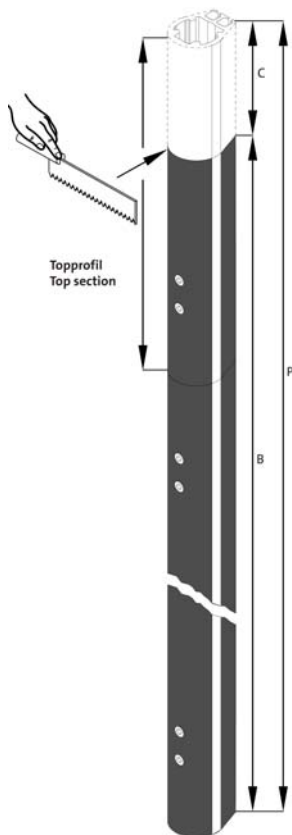

2.6.3 Shortening the top hose

Shorten the top hose by the measurement C..

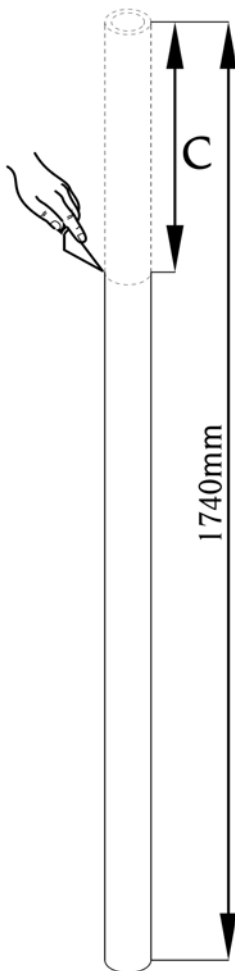

2.6.4 Assembly of bushings and spacer tubes

If your system was delivered with reinforced profiles please continue with the next chapter for the assembly procedure:

Rod headstay:

After assembly of the eye terminal and before cold heading the rod, slide the bushes and spacer tubes onto the forestay from the bottom to the top as shown in the diagram. Fit the 7 top bushes first and then the top spacer which was cut to match the top section. It is important that the order and numbers of bushes and spacer tubes are fitted as shown in the diagram. This will ensure that the 500 mm spacers, which are marked red, will be correctly positioned for each foil section join. With some systems, depending on the total section lengths supplied, there may be a 1500 mm long section of foil. The bush and tube spacings for this particular section are fitted to the lower end of the stay, as illustrated, ensuring that it is situated on final assembly immediately above the feeder (bottom) section. Finally, after fitting all the bushes and spacer tubes in the correct sequence, fit the bushings and hoses for the feeder section according to the following diagram.

Wire headstay:

After fitting the lower terminal and before assembly of the top terminal, the bushes and spacer tubes are fitted from the top to the bottom as shown in the diagram above. Fit the bushings and hoses for the feeder section first. It is important that the order and numbers of bushes and spacer tubes are fitted as shown in the diagram. This will ensure that the 500 mm spacers, which are marked red, will be correctly positioned for each foil section join. With some systems, depending on the total section lengths supplied, there may be a 1500 mm long section of foil. The bush and tube spacings for this particular section are fitted to the lower end of the stay, as illustrated, ensuring that it is situated on final assembly. Finally after fitting all bushes and spacer tubes in the correct sequence, fit the top spacer and 7 bushes to the top end. Before fitting the top terminal, ensure that all the bush spacing is correct and will match the foil join positions.



Note!

For foils R10 and R20 two additional bushings have to be placed at the bottom stay end.

Two additional bushings at R10 and R20

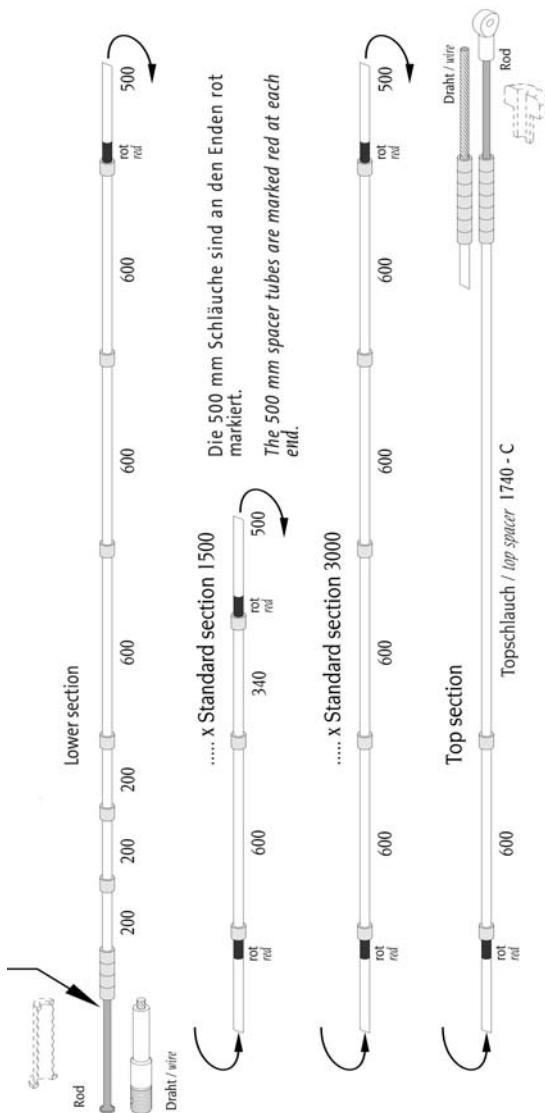

Assembling the furling unit

2.6.5 Foil assembly / split foil connectors

After the assembling of the bushes and hoses on the forestay and the shortening of the top profile start to assemble the profiles.

Sequence of the profiles:

Top section -- x Standard section 3000 -- x

Standard section 1500 -- Lower section

From the bottom end of the stay, slide on and feed the top profile along to the top end of the stay. When in place, assemble a pair of split join sleeves over the stay at the spacer tube, marked red, directly under the top section (fig. 1). Insert a stainless steel plate (1) into the recess on the top half of the join sleeve and make sure that the holes of the plate and the join sleeve are on the same side. Push the join sleeve half of its length into the upper foil section (2). (fig. 2).

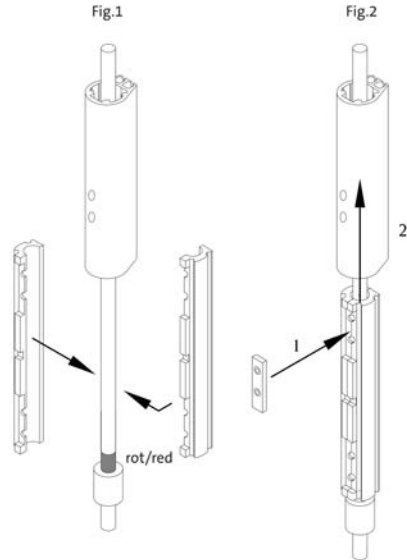

Note!

Ensure that the holes of the connector plate and foil are aligned. Otherwise the Tuff-Lock screws won't fit.

Secure the join sleeve with 2 tuff-lock screws (fig. 3). Slide the next piece of extrusion from the bottom end over the stay up to the join sleeve. Insert the lower stainless steel plate into the recess in the join sleeve (fig. 3). Slide the foil section over the join sleeve (fig.4) until it butts cleanly with the upper section and then secure it with 2 tuff-lock screws (fig.5). This process is repeated until all the foil sections are in place.

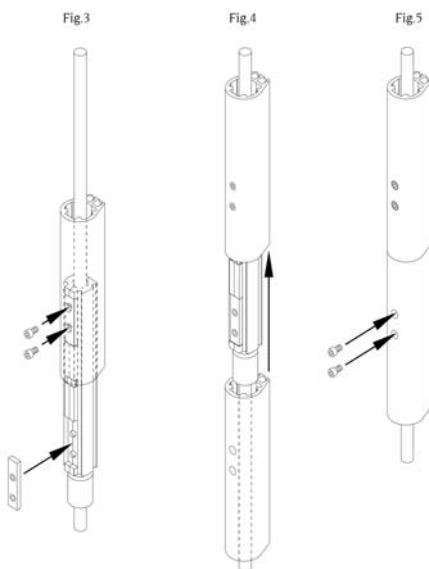

2.7 Installation of the foil reinforcement (optional)

2.7.1 Preparation of the headstay

In some cases a reinforcement of the feeder section is required. The differences regarding the assembly are described in this chapter. If your stay is already assembled, begin as followed:

Unscrew the two security screws of the lower section (fig01) and slide it down off the stay (fig02).

Disassemble the marked bushes and hoses (fig03), they are no longer needed. .



Bild 1 / fig. 1



Bild 2 / fig. 2

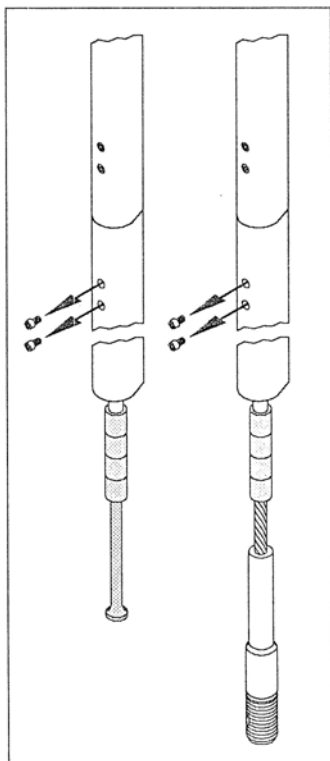

Bild 3 / fig. 3

Assembling the furling unit

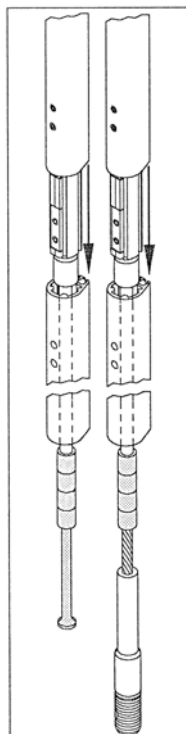
2.7.2 Reinforcement assembly

Place the reinforcement on the stay in the area, in which you have disassembled the bushes and hoses (fig04)

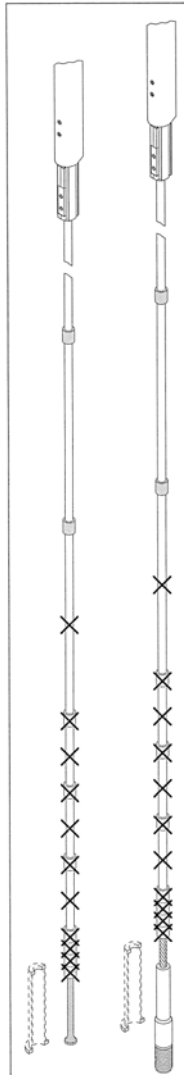

Bild 4 / fig. 4

Thread one end of the small rope through the two holes at the bottom end of the reinforcement and make a loop to knot it.

Thread the other end of it from the top to the bottom end of the lower section. .

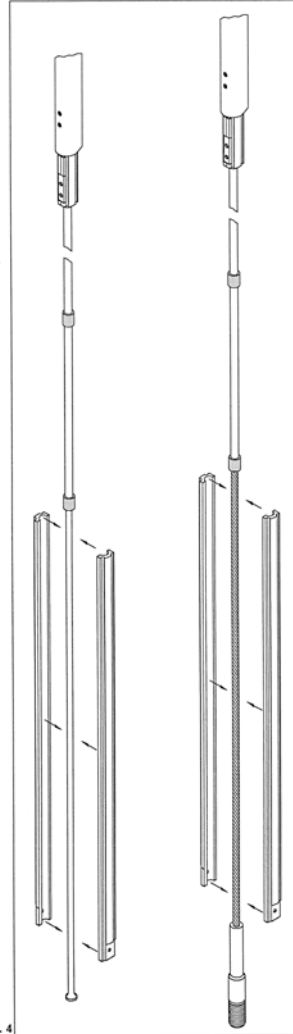

Bild 5 / fig. 5

Assembling the furling unit

Slide the lower section onto the stay and the reinforcement up to the following section. During this action hold the reinforcement in place at the bottom end of the stay using the small rope. (fig 06)

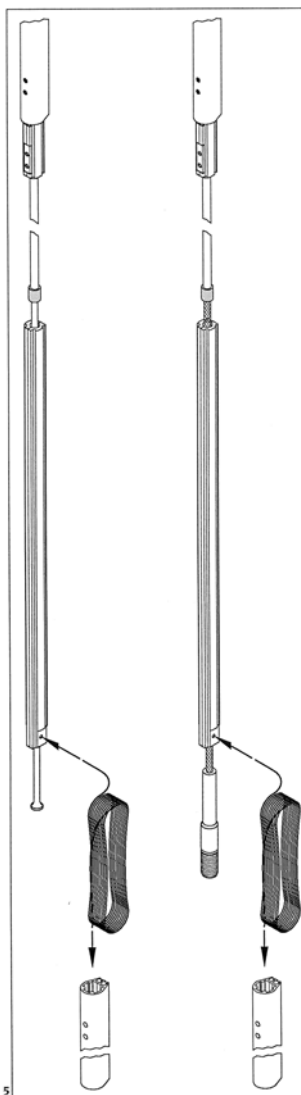

Bild 6 / fig. 6

Remove the small rope from the reinforcement. Insert the lower split bearing into place as shown in the drawing. Push the stay through the furler and insert the lower foil section into the flange. Secure the foil in the flange with the two cap screws provided. (fig07)

Then secure the stay inside the furler, please follow the description in the furler manual.

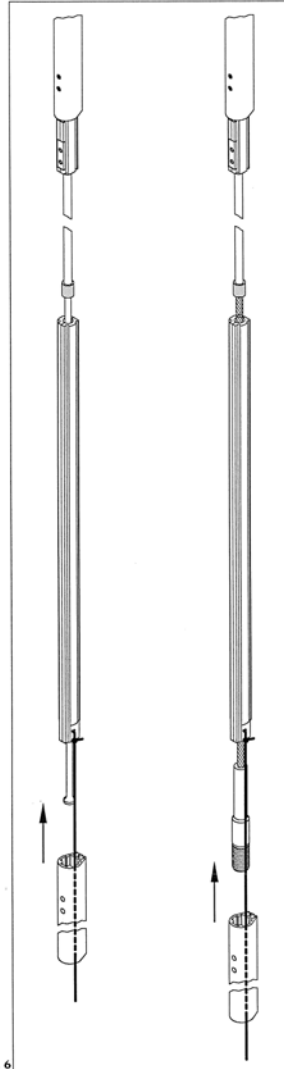
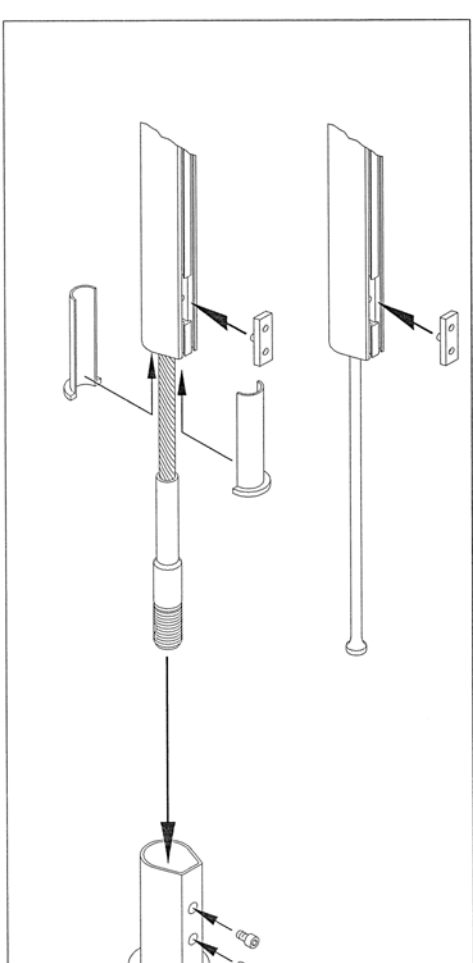

2.8 Headstay length D

The length of the headstay was calculated in the chapter „calculation of stay measurements“. The meaning of the measurement D can be found, according to your headstay geometry (rod stay, wire stay, swage- or swageless top terminal) in the picture on the right.

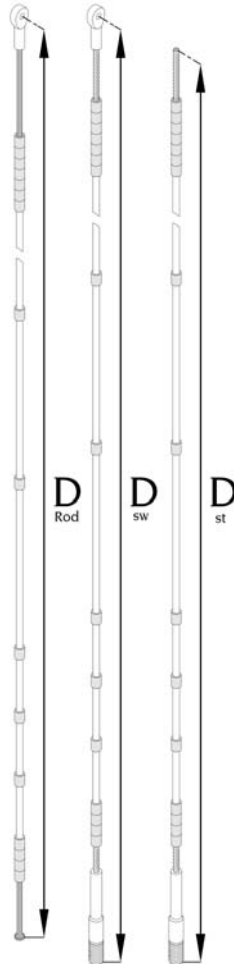

2.9 Assembly of swageless fittings

Cut the wire headstay at the top end to the length D. Install the swageless fitting according to the instructions of the manufacturer.

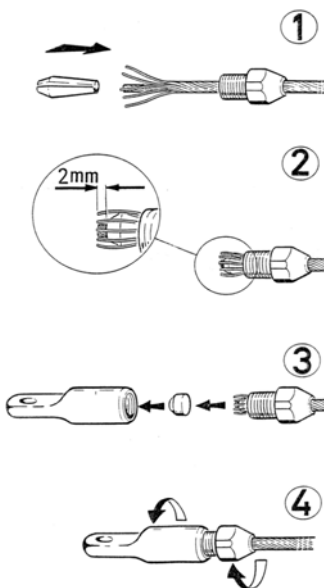

Assembling the furling unit

2.10 Dismantling the adjuster

Withdraw the adjuster locking screw and unscrew the adjuster until it is free from the drum axle. This gives access for fitting the rod retaining brackets or the wire swage nut.

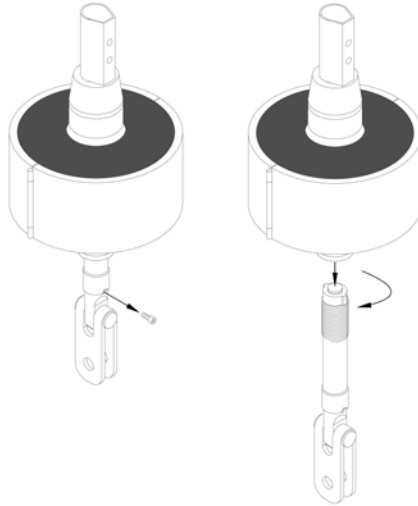

2.11 Installing bottom bearing and halyard swivel

Slide the halyard swivel over the stay and foil section and along into a position above the sail feeder. Check that the swivel travels smoothly over the foil and that it is the correct way up. Temporarily secure in place with tape. Insert the lower split bearing into place.

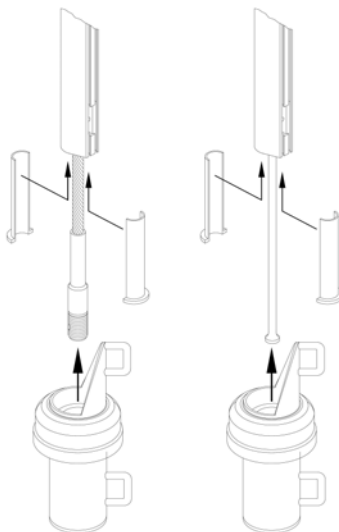

2.12 Assembly of halyard swivel and sail feeder for foils R10 up to R50

When the halyard swivel is on the profile lay the sail feeder in its recess in the foil. Secure it with the clamp and the two provided screws as it is shown on the picture.

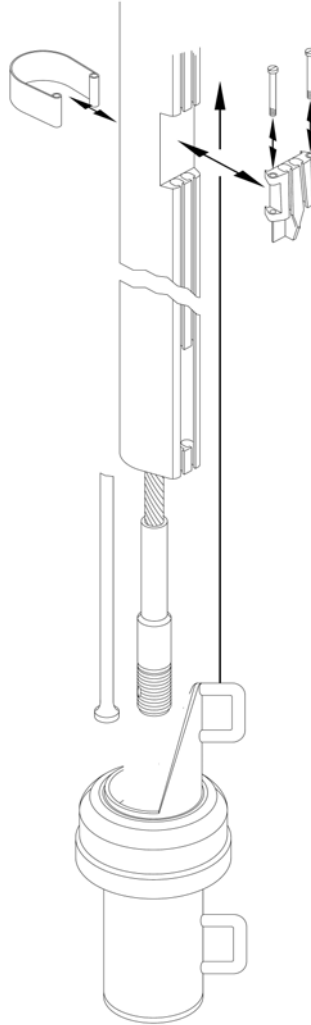

2.13 Connection of foils and drum

Insert the forestay through the drum axle and push the lower foil section into the drum socket. Secure the foil to the drum unit with the two cap screws provided..

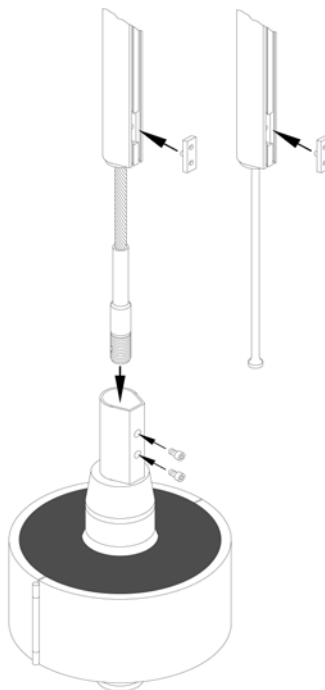

Note!

Risk of corrosion!

Apply Tef-Gel or any similar installation paste between the bottom end of the foil and the furler.

2.14 Securing the headstay in the furler

Slide the forestay out of the drum axle as far as it will go. (It may be necessary to push the rod or wire quite firmly from the top end). For rod forestays, assemble the split retaining brackets around the rod cold head and secure together with the screw provided. For wire forestays screw on the special nut and lock with the screw provided. Pull the headstay from the top as far as possible to ensure that the bottom end is seated correctly within the drum axle. For rod forestays: After every mast dismantling ensure that the retaining brackets security screw is still fixed.

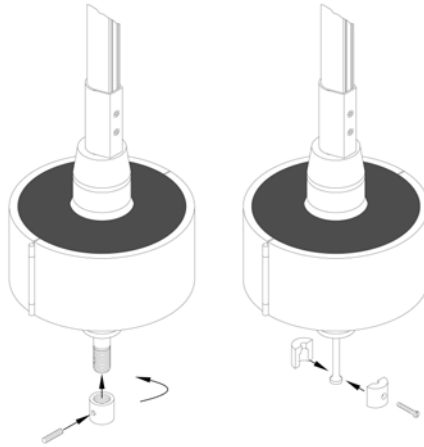

Warning!

If the screw is not properly secured the assembly may fail.
Please secure the screw provided with Loctite or a different derivative.



Note!

To avoid the securing screw from failing, it needs to be secured with a screw securing adhesive (Loctite)

2.15 Assembly of the adjuster

Screw the adjuster back into the axle until no thread is visible. This is the max. elongated position.

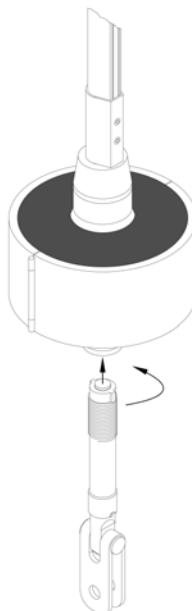

Warning!

During operation, the adjuster has to be screwed in that no thread is visible anymore.
If the adjuster is not enough screwed in it can not tolerate the stay load and may break

2.16 Assembly of the top cap

(as an option)

Ensure that all the delrin bushes are inside the foil section and then insert the top cap into the top profile and secure in place with the two screws provided.

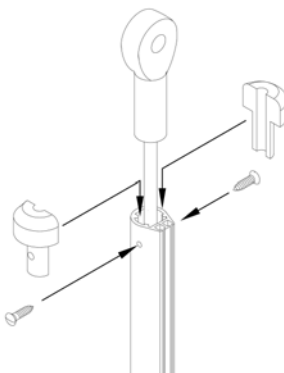

2.17 Installing the furling line

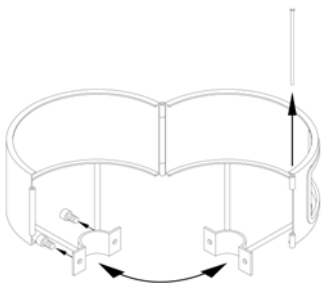

Remove the drum guard by extracting the pin and screws. The drum guard will then unhinge and can be removed from the unit.

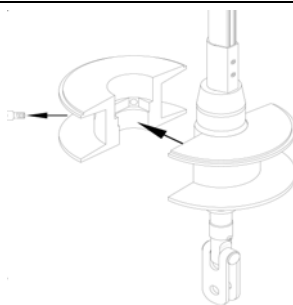

The drum half, which is fitted with a hole for the reefing line, can be removed from the axle by removing the two securing screws.

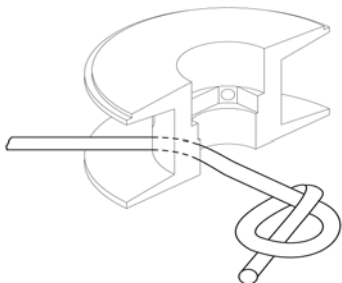

Push the tapered end of the reefing line through the hole and knot it (as small as possible).

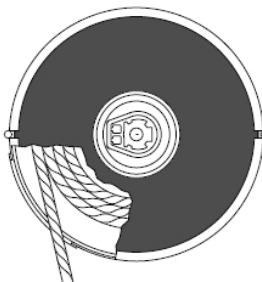

Make sure that the furling line is spooled on the drum according to the direction shown above: Furling the sail means that the drum rotates anti-clockwise.

2.18 Furling line lead

In order to prevent friction between the furling line and the drum guard, the furling line should run from the drum to first lead block at an angle of 90° to the headstay unit. The drum guard can easily be turned and this enables the opening for the furling line to be adjusted in such a way that the furling line always runs in the middle. In order to ensure that sufficient furling line is on the drum, make sure that three turns remain on the drum when the sail is completely furled. WE recommend the furling line to be led via a block at the stern, back to the winch at the cockpit. As can be seen from the illustration, the furling line can be led to the stern either on the port or starboard side.



Warning!

The furling line may break when it is chafing at the drum guard. Please align the guard in a way that the furling line does not chafe.



Tip

To avoid an overload of the knot at the end of the furling line it is useful to have three rounds of furling line remaining on the drum when the sail is fully unfurled.

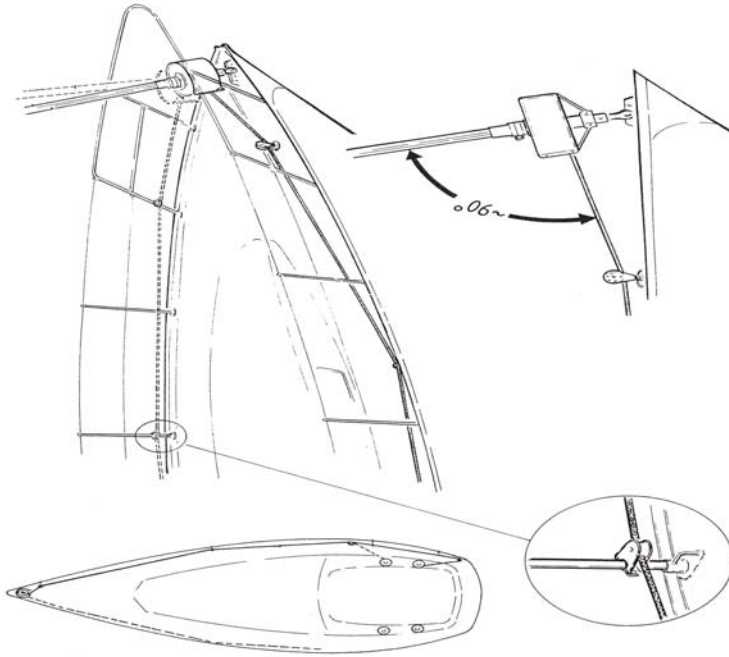

3 Operation of the furler

3.1 Length adjustment of the RS2000

After connecting the furler to the deck chainplate, rotate the adjuster to obtain the required forestay length and tension. Remember to lock the adjuster with the cap screw after any adjustment.

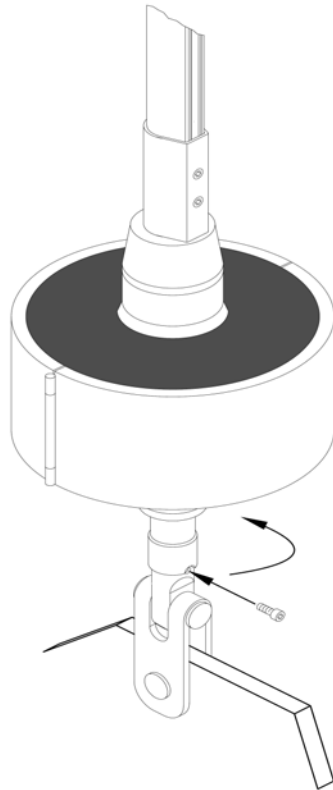

3.2 Racing purposes

For racing, the drum and guard can be totally removed. This will allow full hoist racing sails to be tacked directly onto the deck, permit normal sail changes. Detach the headsail feeder from the section by removing the screw and retaining plate. Slide the halyard swivel down to the top of the furling drum and reattach the headsail feeder. This will allow the use of two halyards and fast sail changes without the interference of the halyard swivel.

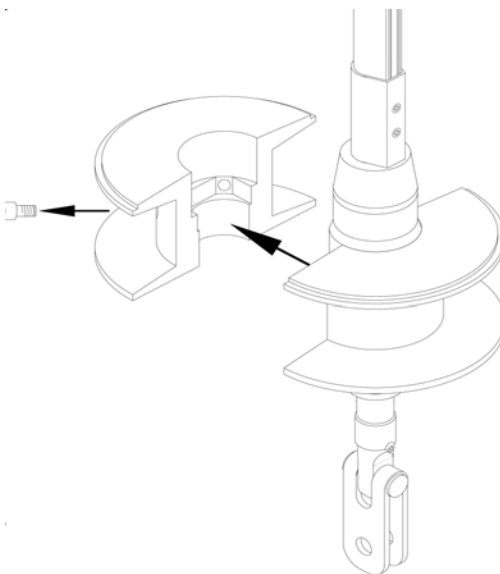

3.3 Configuration of the head

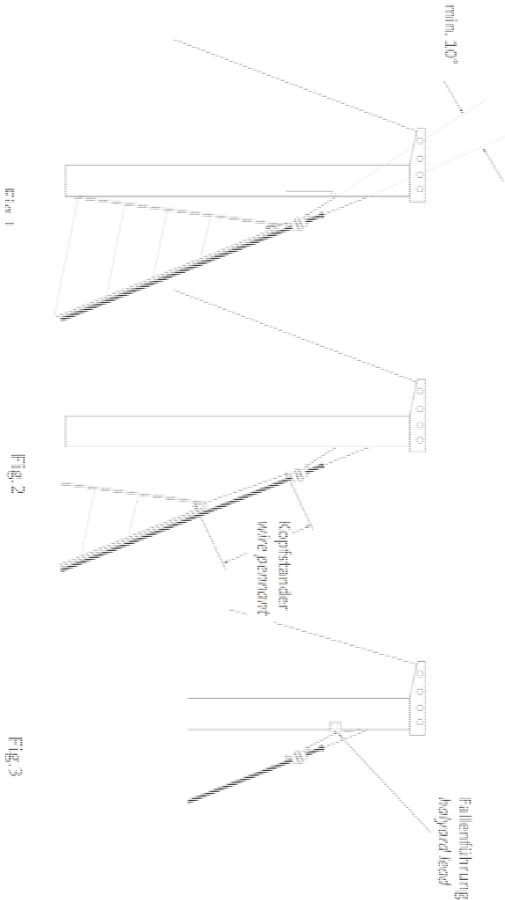

Halyard leads

To prevent the genoa halyard from twisting around the forestay, the angle between forestay and halyard must be at least 10° (fig. 1). If this requirement is not fulfilled, a halyard lead must be fitted.

(fig.3)

Position of the halyard swivel If the boat is equipped with more than one headsail, each one should be given equal luff length so that the halyard swivel will be located at the same level when the sail is hoisted. It is imperative that the halyard shackle is always at the same position at the top, i.e. approx. 20cm from the halyard sheave. If the sails are not cut to the same length, a wire pennant must be fitted to ensure that the halyard swivel is always at the same height when the sail is hoisted. (fig 2)



Note!

The angle between halyard and headstay has to be at least 10° . If the angle is less than 10° a halyard lead has to be installed.

4 specification sheet RS2000

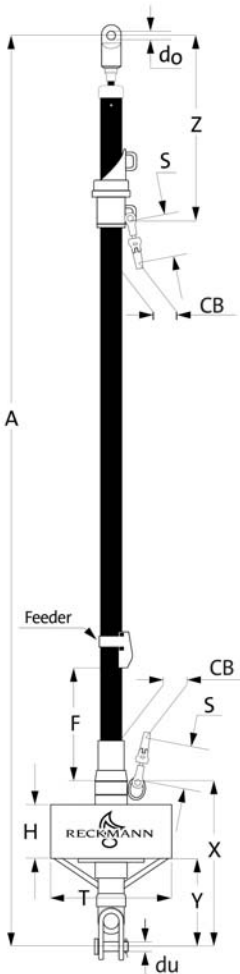

Rod		d. (mm) (lock / hole)	d. (mm) (Bohren/φin)	Z	X min	Y min	T	H	S	F	CB	Verstellweg / adjuster stroke			
Draht (mm) / wire	8 - 12														
RS2000-10	8	13,0	13,0	12,8	355	269	160	181	72,5	60	960	30	60		
	10	13,0	13,0	12,8	355										
	12	16,0	16,0	12,8	363										
	6	13,0	11,5	12,8	SW350 ST378										
RS2000-20	7	13,0	13,5	12,8	SW370 ST386	276	160	198	80,0	80	960	30	60		
	8	16,0	13,5	12,8	SW390 ST390										
	12	16,0	16,0	12,8	400									276	160
	17	16,0	16,0	16,0	400									282	166
RS2000-30	8	16,0	13,5	12,8	SW400 ST400	282	166	223	91,0	80	960	40	70		
	10	16,0	16,0	16,0	SW410 ST420										
	17	16,0	16,0	16,0	438									315	195
	22	19,0	19,0	19,0	454									323	203
RS2000-40/2	30	22,0	22,0	22,0	547	409	258	261	108,0	110	960	40	80		
	40	25,0	25,0	25,0	556	417	266								
	48	29,0	29,0	29,0	561	439	288								
	12	19,5	19,2	22,0	SW540 ST567	409	258								
RS2000-50/2	14	22,5	23,0	25,0	SW580 ST592	417	266	310	120,0	110	1240	30	120		
	48	29,0	29,0	29,0	600	440	269								
	60	32,0	32,0	32,0	612	447	276								
	16	22,5	25,8	29,0	600	440	269								
	19	27,8	29,0	32,0	612	447	276								

Alle Maße in mm, Irrtümer und technische Änderungen vorbehalten.

Measurements given in mm, mistakes And technical changes reserved.

4.1 Reckmann aluminium foil sections

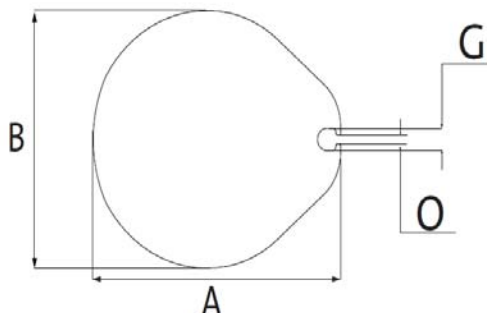
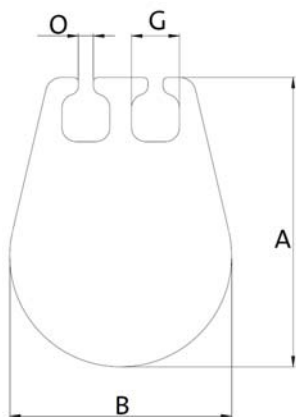

Größe / size	Nut / groove	G (mm)	O (mm)	A (mm)	B (mm)
R10	double	6,4	2,3	31,4	24,1
R20	double	6,4	2,3	35,8	28,8
R30	double	7,5	3,0	45,5	36,1
R40	double	7,5	3,0	49,1	38,7
R50	double	8,0	3,5	54,0	42,0
R5	single	7,5	3,5	60,0	47,0
R6	single	7,5	3,5	72,0	60,0
R7	single	7,5	3,3	85,0	72,0
R8	single	8,0	3,2	107,0	93,0

5 Dealer network and service stations

Denmark

Southern Spars
Torben Jacobsen
Bergensvej 6
DK-6230 Rødekro
T.: +45 74 620060
F.: +45 74 630543
info@southernspars.com

With Marine A/S
Leangbutka 31
N - 1392 Vette
T.: +47 66 79 89 14
F.: +47 66 79 74 83
info@withmarine.no

Quantum Sail Design Group
Jan Hansen
Amager Strandvej 50
DK-2300 København
T.: +45 7026 1296
F.: +45 3296 1276

Elvstrøm Sobstad Norge A/S
Espen Kamperhaug
Sjøsenteret Vallø-PO Box 148
N - 3166 Tolsvrød
T.: +47 3341 4141
F.: +47 3341 4142
info@elvstrom-sobstad.no

Sweden

Sellpower Nordic AB
Magnus Wosse
Baggakersgatan 4a
SE - 43153 Mölndal
T.: +46 31 761 85 80
F.: +46 31 876 535
info@sellpower.se

Norway

Southern Cross Spars A/S
Sandviksvn 120
N - 1363 Høvik
T.: +47 959 77482
F.: +47 9720 18 18
ed@southerncross.no

United Kingdom

HYS Rigging
Dennis Fisher
Port Hamble
GB- Hampshire SO31 4NN
T.: +44 2380 454111
F.: +44 2380 455682
rigging@hambleyachtservices.co.uk

Netherlands

A+ Rigging Nederland B.V.
Zeldenrust 7
NL-1671 GW Medemblik
T.: +31 227-544096
F.: +31 227-544158
info@aplusrigging.nl

Italy

G&G Rigging srl
Walter Giovanelli
Via Mazzini 33
I-20099 Sesto S. Giovanni
T.: +39 02 454 811 90
F.: +39 02 365 138 95
info@gegrigging.com

France

Gréement Import
13 Rue du Chêne Lassé - BP
F-44803 Saint - Herblain
T.: +33 2 28 03 01 01
F.: +33 2 28 03 19 91
bb@greementimport.fr

Spain

Yachttech
Oliver Blume
C /Ca'n Valero 40, Nave
E-07011 Palma de Mallorca
T.: +34 971 200052
F.: +34 971 296504
info@yachttech.net

Dealer network and service stations

Croatia

ASPAR Rigging
Luzine bb
CRO-51000 Rijeka
T.: +385 51 674 031
F.: +385 - 51 674 031
aspar-rigging@ri.t-com.hr

Sinera Rigging
Psg. Joan de Borbó 92
E-08039 Barcelona
T.: +34 932 254 934
F.: +34 932 251 949
info@sinerarigging.com

Slovenia

DNA d.o.o.
Miha Spendal
Kantetova 85
1000 Ljubljana
T.: +386 41 730 970
F.: +386 12776 606
dnamsp@siol.net

Malta

XS Marine Ltd.
James Xuereb
26, Paul Borg Str.
Attard, Atd 2632
T.: +356 7900 9300
F.: +356 2141 3894
info@xs-marine.com

Greece

Kafetzidakis Sails
Kostas Kafetzidakis
90 Tzavella
GR-18533 Piraeus
T.: +30 210 413 74 38
F.: +30 210 413 16 24
info@kafetzidakis.gr

Turkey

UTL / Skiper
Muhane cad. Akce sokak no 10/4
Karakoy
Istanbul
T.: +90 212 292 90 98
F.: +90 212 292 91 93
info@skiper.org

New Zealand

Southern Spars Ltd.
15 Jomac Place
Avondale
NZ-1026 Auckland
T.: +64 9 8457200
F.: +64 9 3583309
info@southernspars.com

New Zealand Rigging Ltd.
31 Woodside Ave - Northcote
NZ- Auckland
T.: +64 9 480 8090
F.: +64 9 480 9190
bart@nzrigging.com

Australia

Riggtech
Phill Bate
Royal Prince Alfred Yacht Club
2/16 Mitala Street,
P.O. Box 812
AUS - 2106 Newport Beach
T.: +61 2 9997 8100
F.: +61 2 9979 6848
info@riggtech.com.au

Caribbean

Antigua Rigging Ltd.
Stan Pearson
English Harbour
Antigua, West Indies
T.: +1 268 4638575
F.: +1 268 5621294
info@antiguarigging.com

FKG Marine Rigging
Kevin Gavin
37 Wellington Road
99998 St. Maarten
Netherlands Antilles
Tel. +599 544 4733
Fax. +599 544 2171
kevin@fkg-marine-rigging.com

USA

Nance and Underwood
262 Southwest 33rd st.
USA - FT Lauderdale, FL 33315
T.: +1 954 764 6001
F.: +1 954 764 5977
nanceandunderwood@aol.com

Euro Marine Trading, Inc.
Siebe Noordzy
62 Halsey Street, Unit M
USA– Newport, RI 02840
T.: +1 401 849 0060
F.: +1 401 849 3230
info@euromarinetrading.com

Florida Rigging & Hydraulics, Inc.
3905 Investment Lane, Suite 9
USA– Riviera Beach, FL 33404
T.: +1 561 8637444
F.: +1 561 8637711
cehinger@rigginghydraulics.com



Dealer network and service stations

Offshore Spars
Mike Feldmann
50200 E.Russell Schmidt Blvd.
USA– Chesterfield, MI 48051
T.: +1 586 598 4700
F.: +1 586 598 4705
mike@offshorespars.com

Rigworks Inc.
Ray Pope
2540 Shelter Island Drv.
USA - San Diego , CA 92106
T.: +1 619 223 3788
F.: +1 619 223 3099
info@rigworks.com

Rigg Pro
14 Regatta Way
USA - Portsmouth, RI 02871
T.: +1 401 683 2151
F.: +1 401 683 7878
john.b@southernspars.com

6 Index

- Adjuster stroke: 16
- Assembling the furling unit 15
- Assembly of bushings and spacer tubes 23
- Assembly of halyard swivel and sail feeder for foils R10 up to R50 39
- Assembly of swageless fittings 35
- Assembly of the adjuster 42
- Assembly of the top cap 42
- Calculating B, C und D 16
- Configuration of the head 47
- Connection of foils and drum 40
- Dealer network and service stations 53
- Foil assembly / split foil connectors 27
- Foil assembly from R10 up to R40 19
- Furling line 10
- Furling line lead 44
- Furling systems with rod headstay after storage 14
- Headstay length D 35
- How to use this manual 9
- Important remarks 9
- Installation of the foil reinforcement 28
- Installing bottom bearing and halyard swivel 38
- Installing the furling line 43
- Introduction 5
- Length adjustment of the RS2000 45
- Maintenance of the furler 13
- Maintenance to be carried out by a Reckmann service partner 13
- Maintenance to be carried out by the customer 13
- measurement A 15
- Operation of the furler 45
- Packing list 5
- Preparation of the headstay 28
- Preparation of the top cap 20
- Racing purposes 46
- Reckmann aluminium foil sections 52
- Reinforcement assembly 31
- Required drill bit diameter for top cap assembly 20
- Sailing with a reefed sail 10
- Securing the headstay in the furler 41
- Shortening the top foil 21
- Shortening the top hose 22
- specification sheet RS2000 50
- Toggle 12
- Tools required for assembly 15

RECKMANN
