

maxJ

The Reckmann “maxJ” furling gear is a manual below deck system. The system combines the advantages of a genoa reefing system with those of a standard tuff-luff forestay: maximum sail area with the possibility to furl the genoa. The system is equipped with a spectra furling line and carbon foils.

NEW DESIGN!

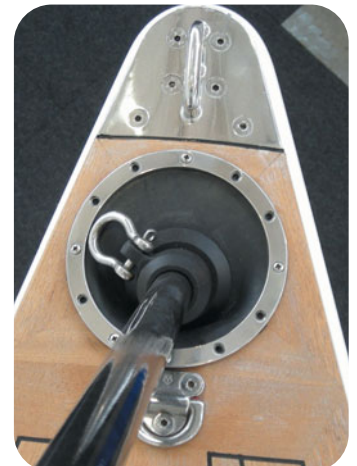
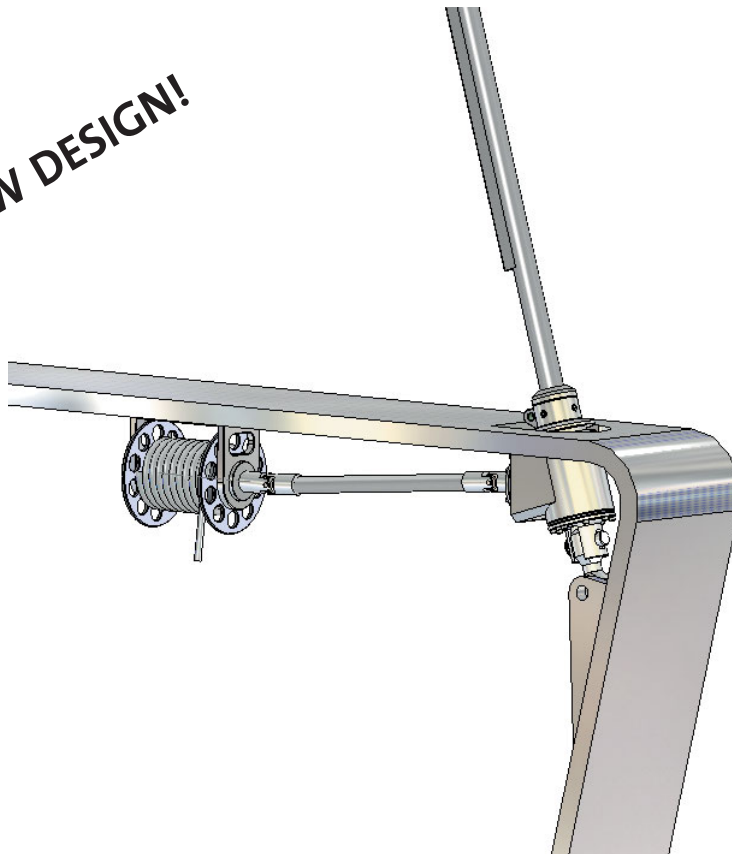

installation on Baltic 50



below deck mounted drum

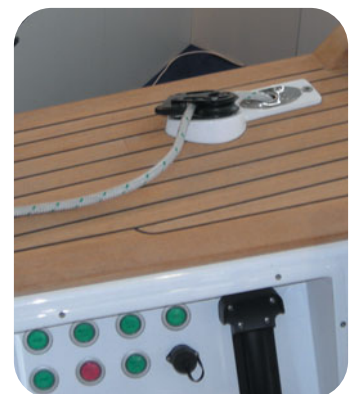

furling rope

technical data

boat length:	35 - 50 ft
maximum Rod size:	-30
carbon foil size:	S2